

Homework 09, Problem 3; due 11/20/09.

Instead of Weste and Harris Problems 12.9 and 12.10, start with the lab amplifier.

1. Create a new OP_AMP_Test2 with a series load resistor and capacitor as shown below. (To create OP_AMP_Test2, first copy OP_AMP_Test to OP_AMP_Test2 and then modify the schematic.)

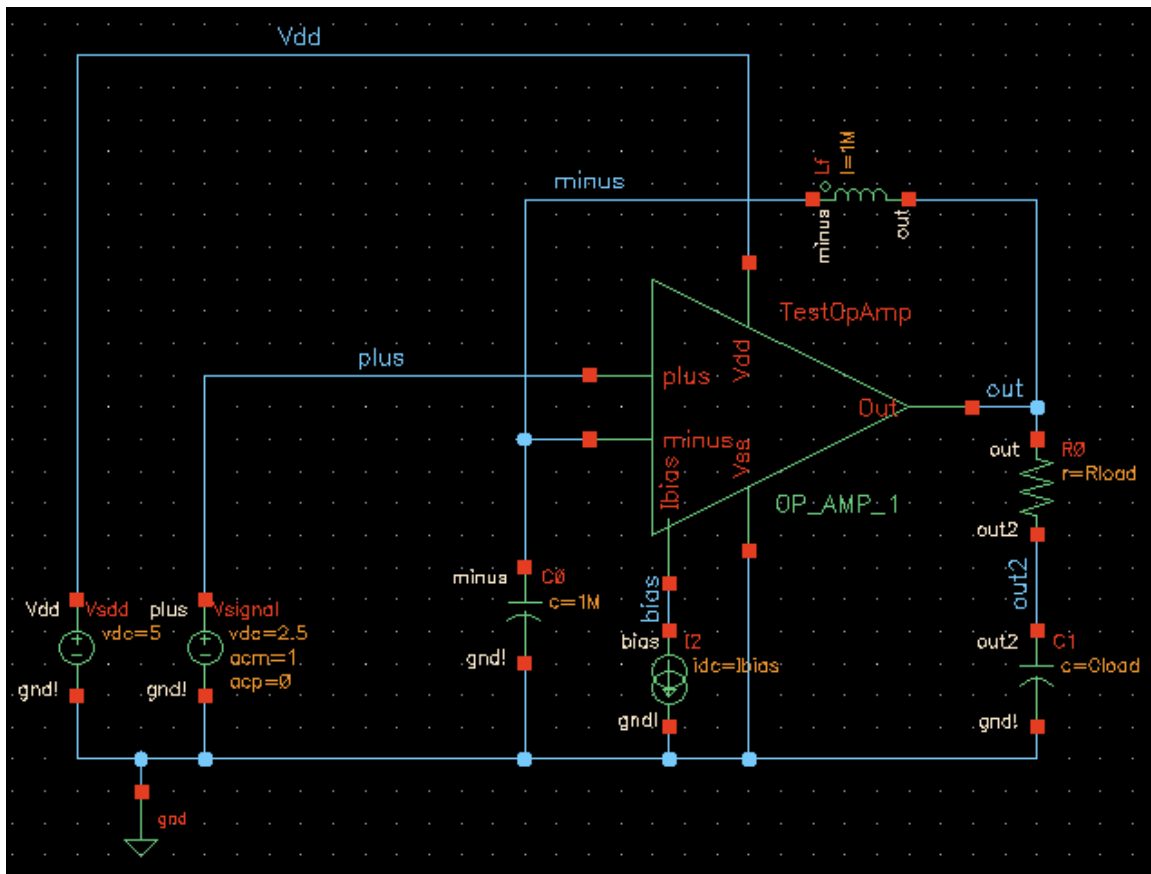

Set the values for the resistor and capacitor to Rload and Cload.

2. Start the Analog Environment and set the simulator to spectreS. You can then load a state that you saved from OP_AMP_Test by using Session->Load State. In the Load State Dialog, change the cell from OP_AMP_Test to OP_AMP_Test2 and the states that you saved should appear. Load a state with the improved variables.

3. As in the lab, run Simulation->Netlist->Create Raw to load the new variables from the load resistor and capacitor. Set the variables to Rload = 10K and Cload = 1u.

4. Run the simulation. How much has the gain decreased with the additional load?

5. Back in the OP_AMP_Test2 schematic, change the op amp to OP_AMP_2, the one with the source follower output. You can easily do this by accessing the properties of the

op amp (“q”) and changing the name of the cell from OP_AMP_1 to OP_AMP_2. The new op amp has four additional transistor whose sizes are set with four additional variables. Set the variables appropriately. (The nmos mirror transistors should be similar to the pmos mirror sizes and the Source Follower should be similar to the common source transistor.)

6. Run the simulation. Has the source follower improved the gain? By how much?

Please return a combined gain plot for the two amplifier and gain and phase plots for each of the two amplifiers.

7. Extra Credit: How much can you further increase the gain by adjusting the variables?

Hint: Under the Analog Environment Tools menu, you can select Tools->Parametric Analysis...

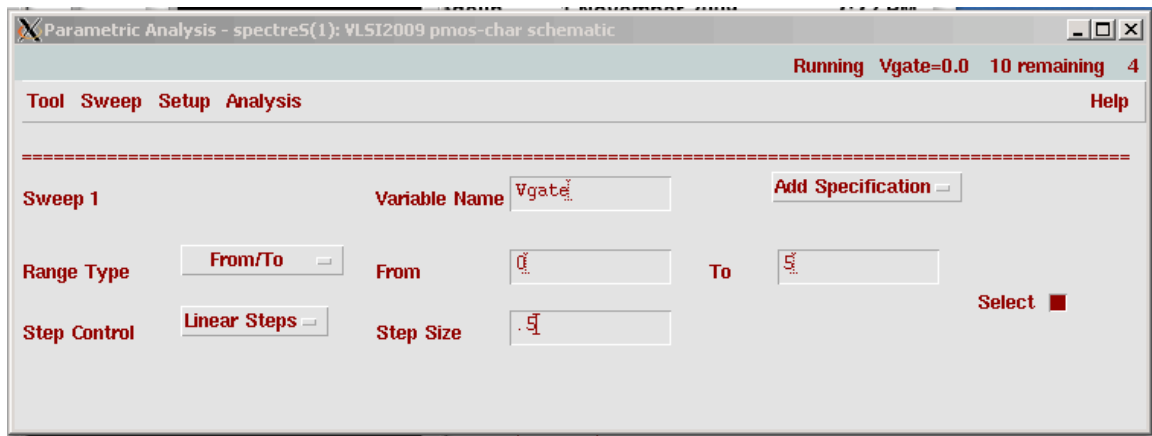

Using this tool, you can sweep variable values and generate multiple plots for the various values. For example, you could sweep W_{in} from 2μ to 20μ in steps of 2μ . Once the variable sweep is set, select Analysis->Start to start the set of simulations. The multiple lines from the results will be plotted.